

**-1(X) LATCH ASSY
ROTATED TO SHOW
INSTALLATION ATTITUDE**

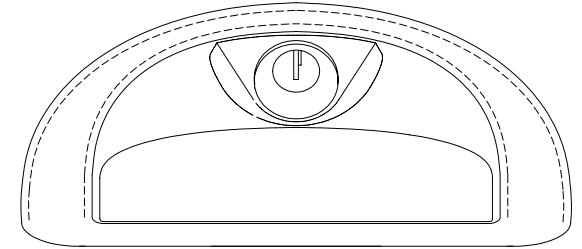

-3(X) LOCKING LATCH ASSY

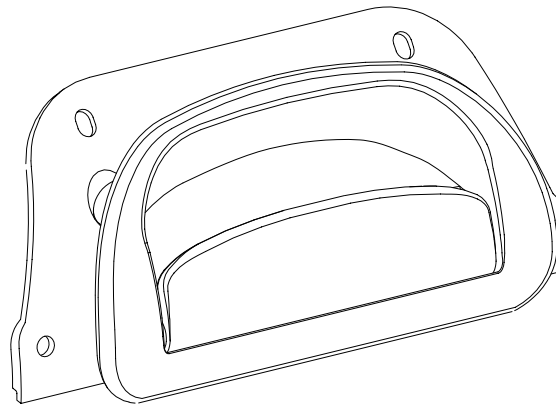

-1(X) LATCH ASSY

MATERIAL:
 BEZEL & BACK PLATE: ULTEM
 HOOK & HANDLE: ALUM
 STRIKE BODY: ALUM
 STRIKE ROLLER: NYLATRON
 LOCK BODY: ALUM
 LOCK: STEEL & BRASS

FINISH:
 BEZEL & BACK PLATE: N/A
 HOOK & HANDLE: BRUSH FINISH, ANODIZE
 STRIKE BODY: BRUSH FINISH, ANODIZE
 STRIKE ROLLER: N/A
 LOCK BODY: MAT FINISH, ANIDIZE
 LOCK: CROME PLATE

GENERAL: (X) DESIGNATES COLOR MATCH

WEIGHT:
 -1(X) LATCH ASSY: .25 LBS MAX
 -2 STRIKE ASSY: .10 LBS MAX
 -3(X) LOCKING LATCH ASSY: .42 LBS MAX

ALL INFORMATION ON THIS DRAWING IS PROPRIETARY TO HARPER ENGINEERING COMPANY.

All design, manufacturing, reproduction, use and sale rights regarding the same are expressly reserved except that this drawing may be reproduced by: the government of the United States of America only for distribution to government activities and/or personnel for purposes of maintenance, supply identification, stock listing and other related uses. All patent rights hereto are expressly reserved by

Harper Engineering Co.

UNLESS OTHERWISE SPECIFIED

ALL DIM ARE REFERENCE

DIMENSIONS ARE IN INCHES $\pm .010$
 ANGULAR DIMENSIONS ARE IN DEGREES $\pm 1^\circ$
 BREAK ALL CORNERS
 INTERNAL & EXTERNAL RADII .030 MAX
 MAXIMUM DRAFT 2°

Code Ident No.

34941

Harper Engineering Co.



200 S. Tobin St. Renton, Washington 98055

TITLE H3-1670 PULL LATCH ASSY -
STOWAGE COMPARTMENT